



# Sistema Europeo

## Corredizas y fijas

Window World



**CATALOGO GENERAL DEL SISTEMA  
CORREDIZO EUROPEO**

# ÍNDICE

Generalidades.....	2
Configuraciones posibles.....	2
Secciones de perfiles.....	3
Ensamble:	
Sistema 2 hojas + malla / Sistema 3 carriles.....	7
Sistema 2 hojas + malla + fijo inferior / Sistema 3 carriles.....	7
Sistema 2 hojas + malla + fijo superior / Sistema 3 carriles.....	8
Sistema 3 hojas + malla / Sistema 4 carriles.....	8
Sistema 3 hojas + malla / Sistema 3 carriles.....	8
Sistema 3 hojas + 2 mallas / Sistema 3 carriles.....	9
Sistema 4 hojas + 2 mallas / Sistema 3 carriles.....	9
Sistema 4 hojas + malla / Sistema 5 carriles.....	10
Sistema 5 hojas + 2 mallas / Sistema 4 carriles.....	10
Sistema 5 hojas + malla / Sistema 6 carriles.....	11
Sistema 6 hojas + 2 mallas / Sistema 4 carriles.....	11
Detalles de cortes de piso.....	12

## GENERALIDADES DEL SISTEMA EUROPEO

	Mínimo	Máximo
Alto de la hoja:		2700 mm
Ancho de la hoja:		1300 mm

Dimensión del perfil de hoja:	26.9mm x 66.3mm
Dimensión del perfil de marco:	2 rieles: 74.8mm x 44.4mm 3 rieles: 110mm x 44 mm
Peso máximo:	120 kg
Espesor máximo de vidrio:	11-19 mm

## CONFIGURACIONES POSIBLES

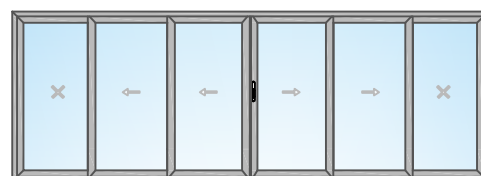
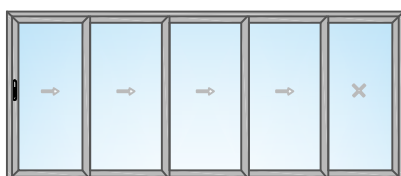
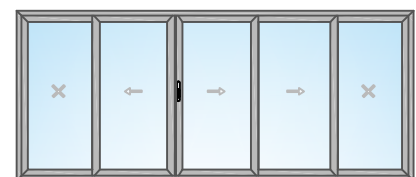
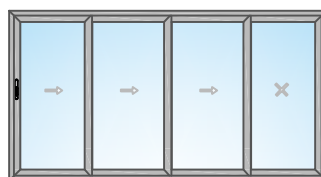
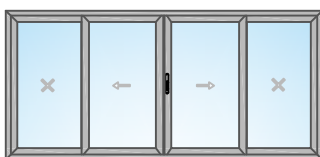
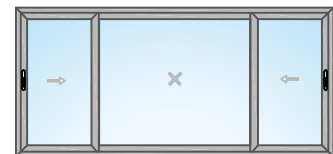
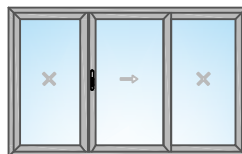
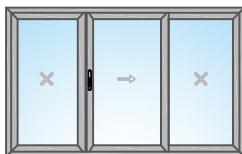
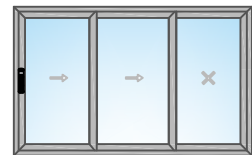
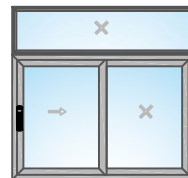
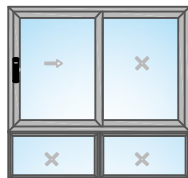
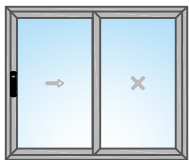

Escala 1:1

Secciones genéricas

Sección B-B'

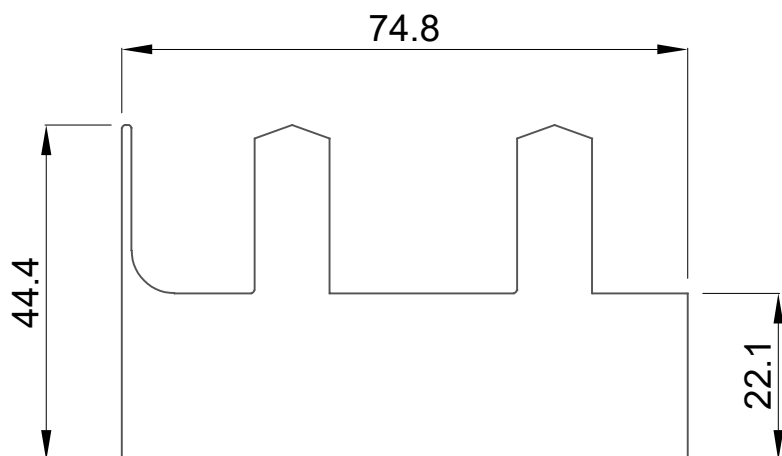

**FI-3445**  
MARCO 2 RIELES

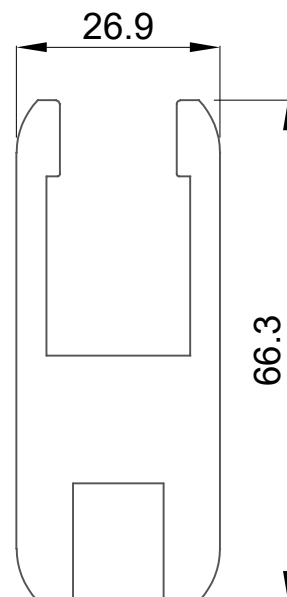

**FI-3446**  
HOJA CORREDIZA

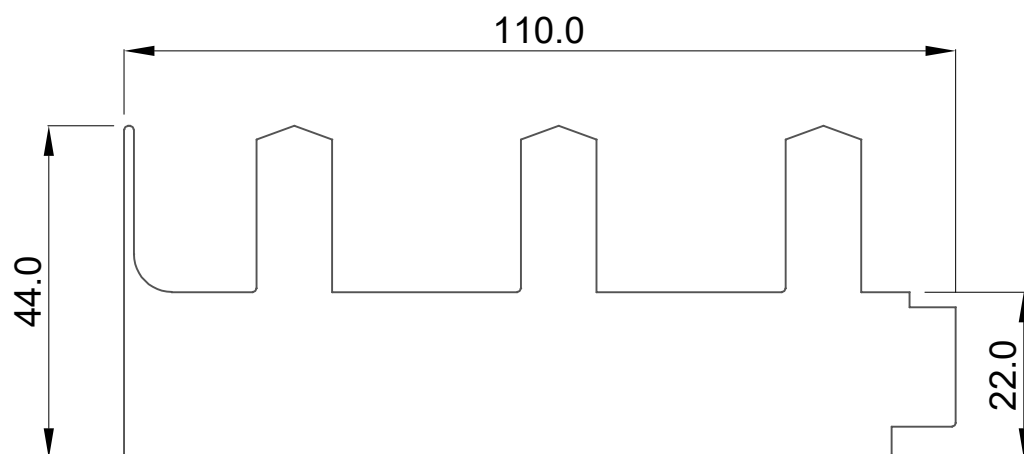

**FI-5179**  
MARCO 3 RIELES

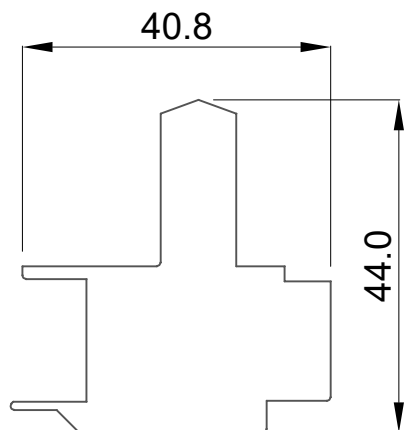

**FI-5181**  
ADAPTADOR PARA  
MARCO 3 RIELES

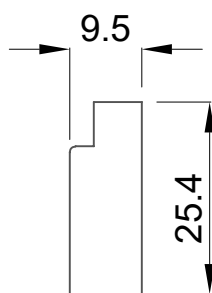

**FI-277**  
PERFIL MALLA

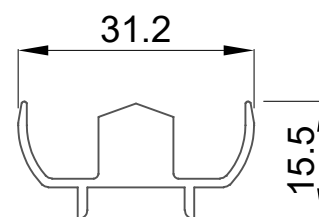

**FI-3485**  
ADAPTADOR DE HOJA

Escala 1:1

Secciones genéricas

Sección B-B'

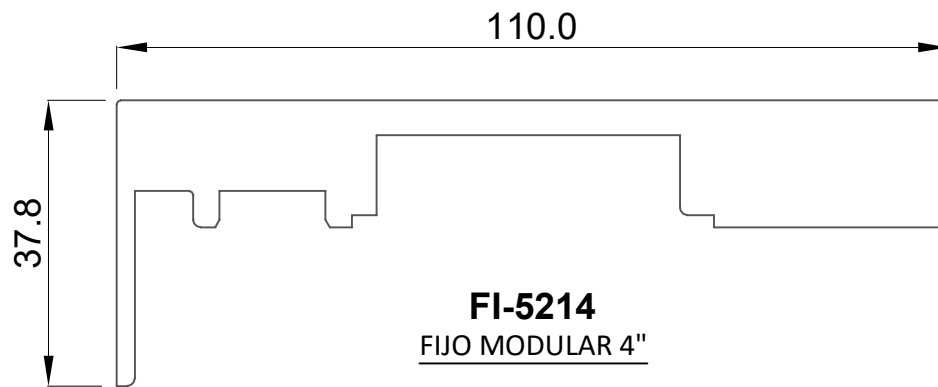

**FI-5214**  
FIJO MODULAR 4"

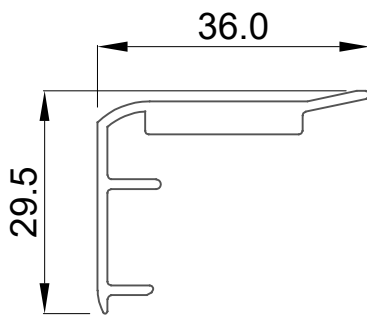

**FI-3447**  
ENTRECIERRE

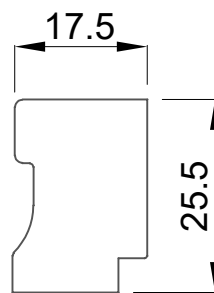

**FI-5123**  
JUNQUILLO CLIPADO

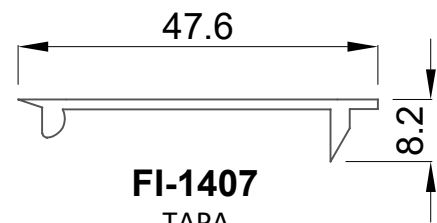

**FI-1407**  
TAPA

Escala 1:2

Secciones genéricas

Sección B-B'

## Corte Vertical

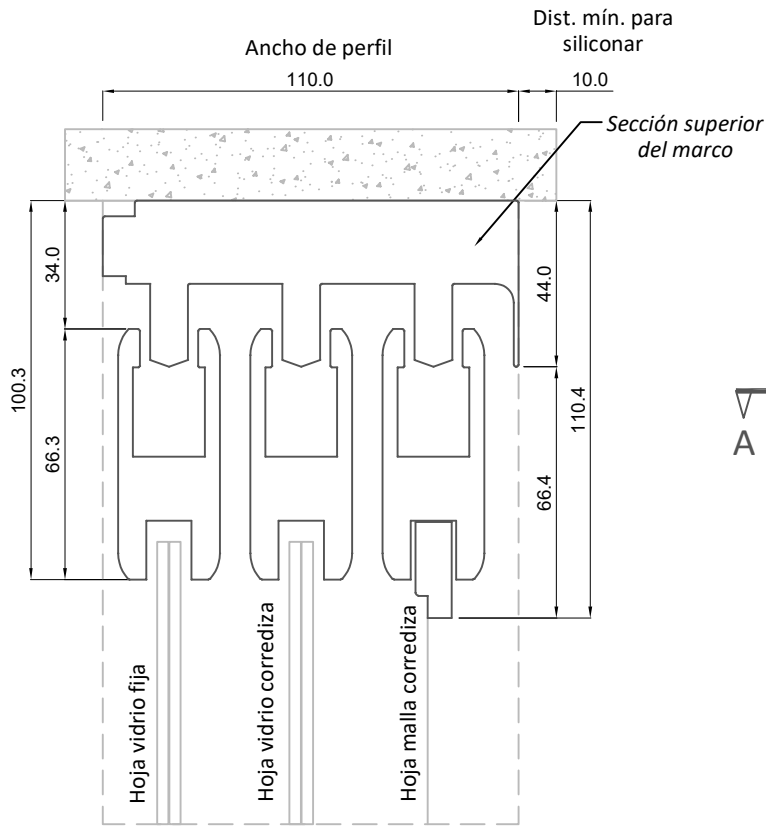

## Ventana Genérica 3 Carriles: 2 hojas + 1 malla

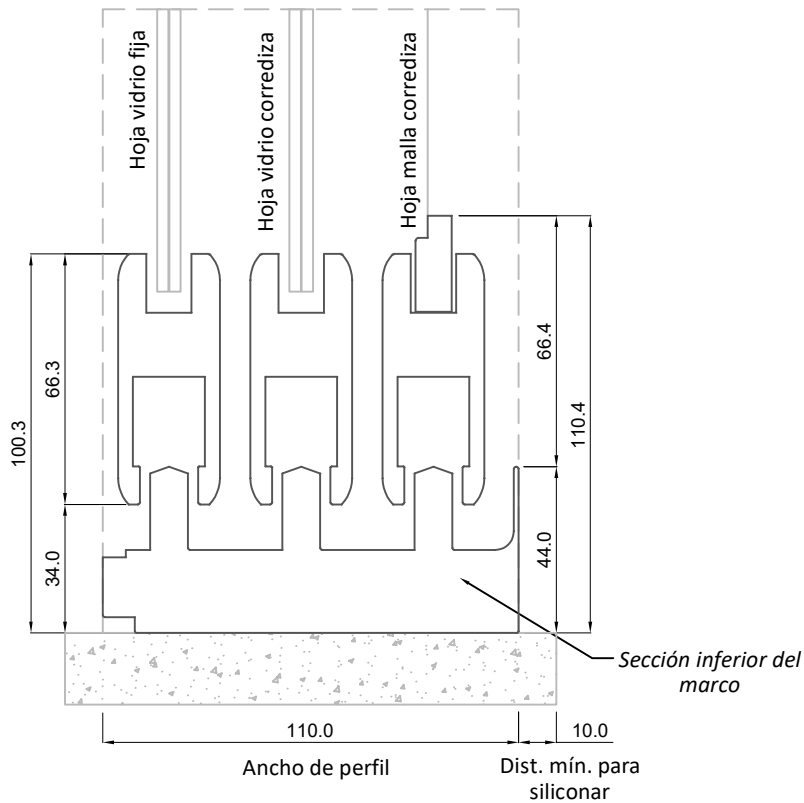
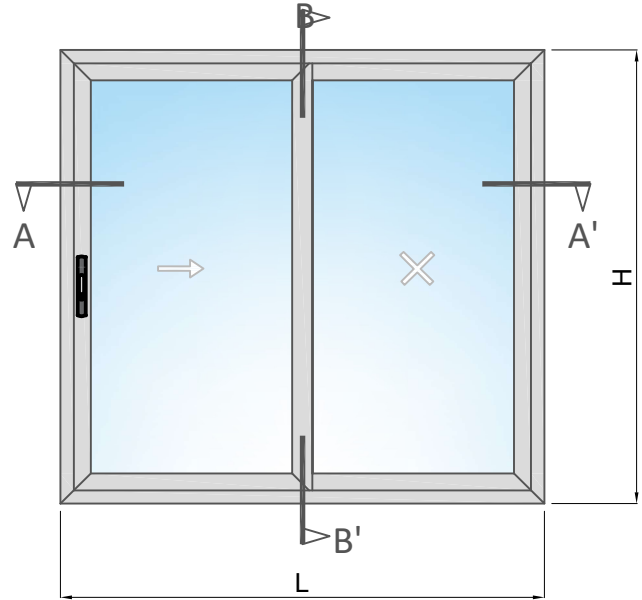

## Detalle de espesor de vidrio

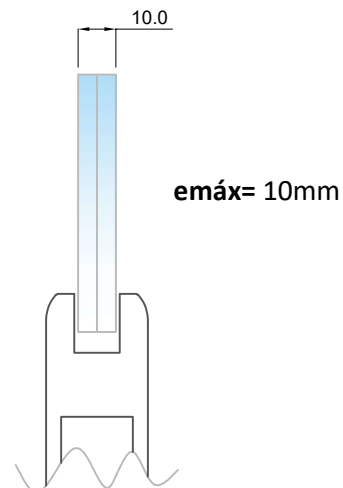

Unidades en milímetros

## Secciones genéricas

Escala 1:2

Sección A-A'

### Corte Horizontal

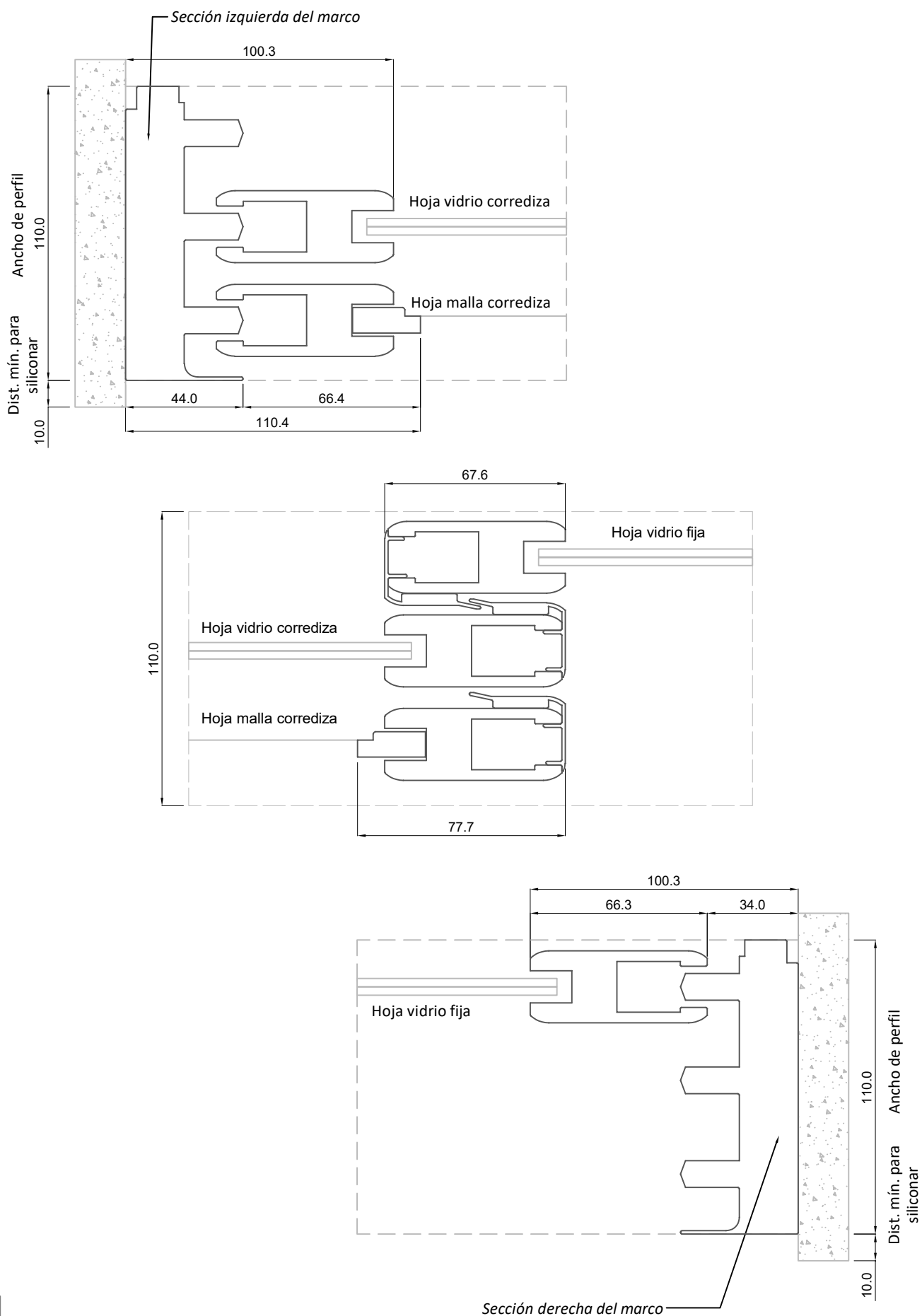

## Europeo 3 carriles

Escala 1:5

Sistema 2 hojas + Malla

**Nota:**

- La malla es opcional. Al considerarse sin malla se usaría el marco de 2 rieles FI-3445.

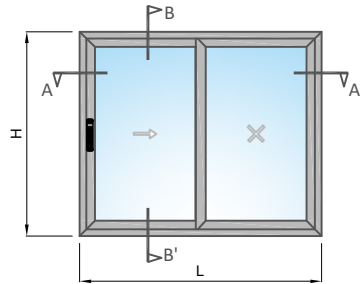

Corrediza por interior  
Sección B-B'

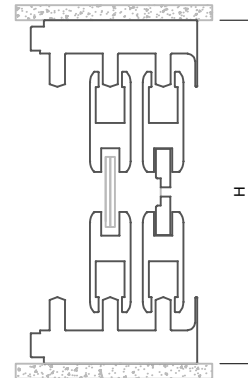

Corrediza por interior  
Sección A-A'

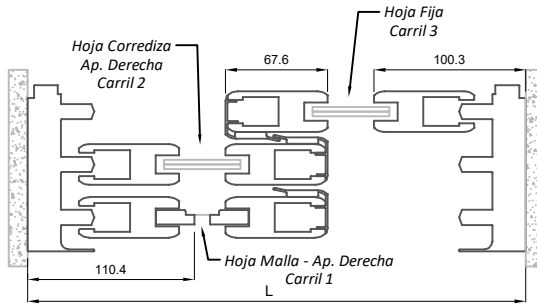

Corrediza por exterior  
Sección B-B'

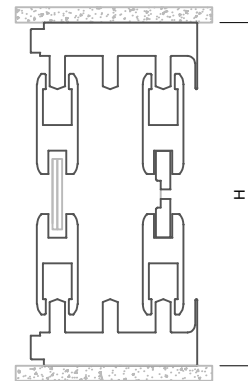

Corrediza por exterior  
Sección A-A'

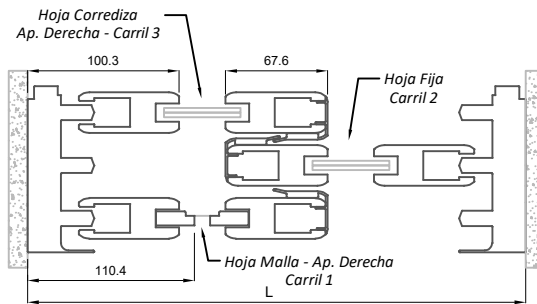

## Europeo 3 carriles

Escala 1:5

Sistema 2 hojas + Malla + Fijo inferior

**Nota:**

- La malla es opcional.

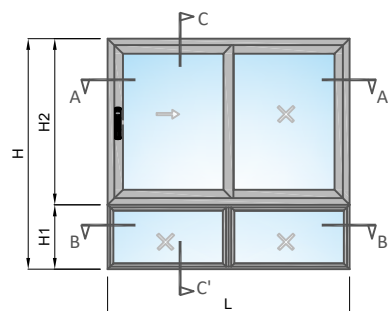

Sección C-C'

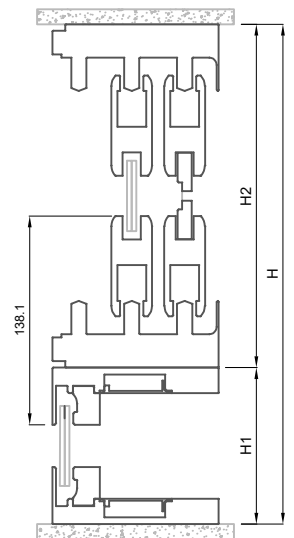

Sección A-A'

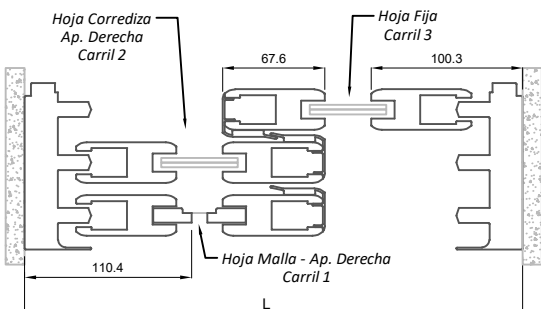

Sección B-B'

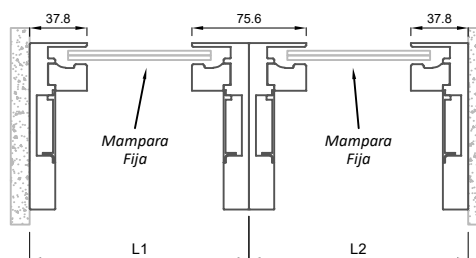



## Escala 1:5

## Europeo 3 carriles

Sistema 2 hojas + Malla + Fijo Superior

**Nota:**

- La malla es opcional.

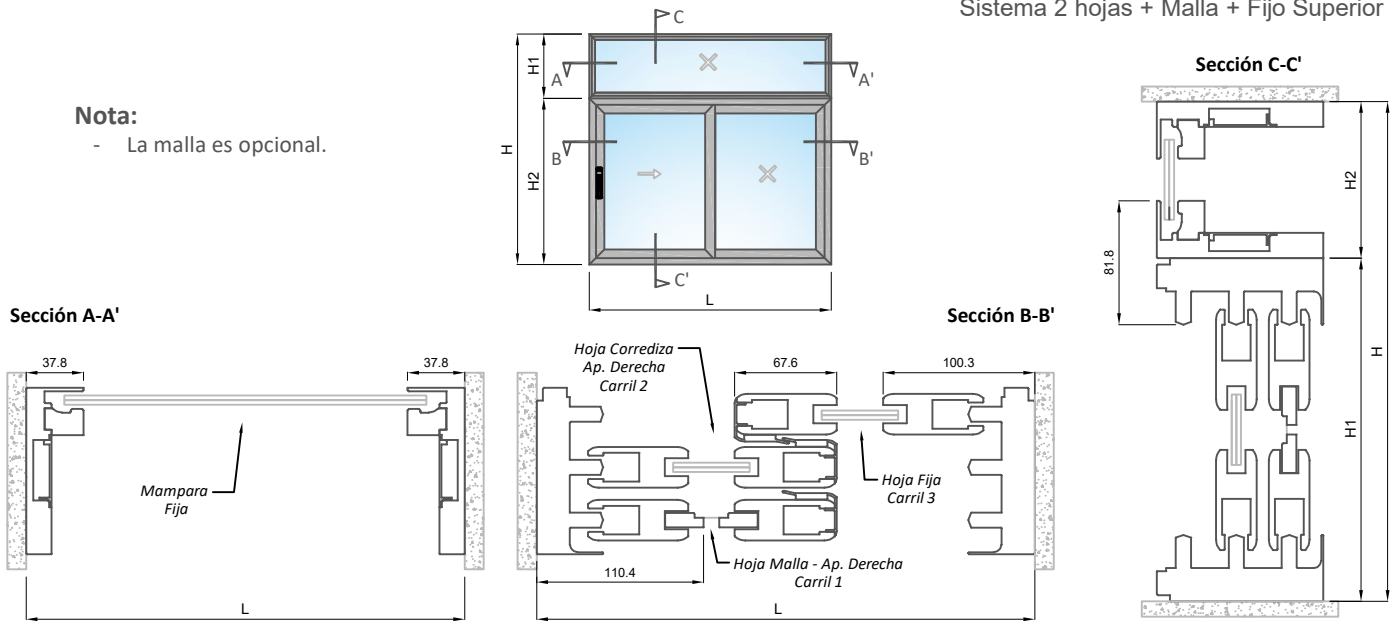

## Escala 1:5

## Europeo 4 carriles

Sistema 3 hojas + Malla

**Nota:**

- La malla es opcional. Al considerarse sin malla se usaría 1 riel menos.

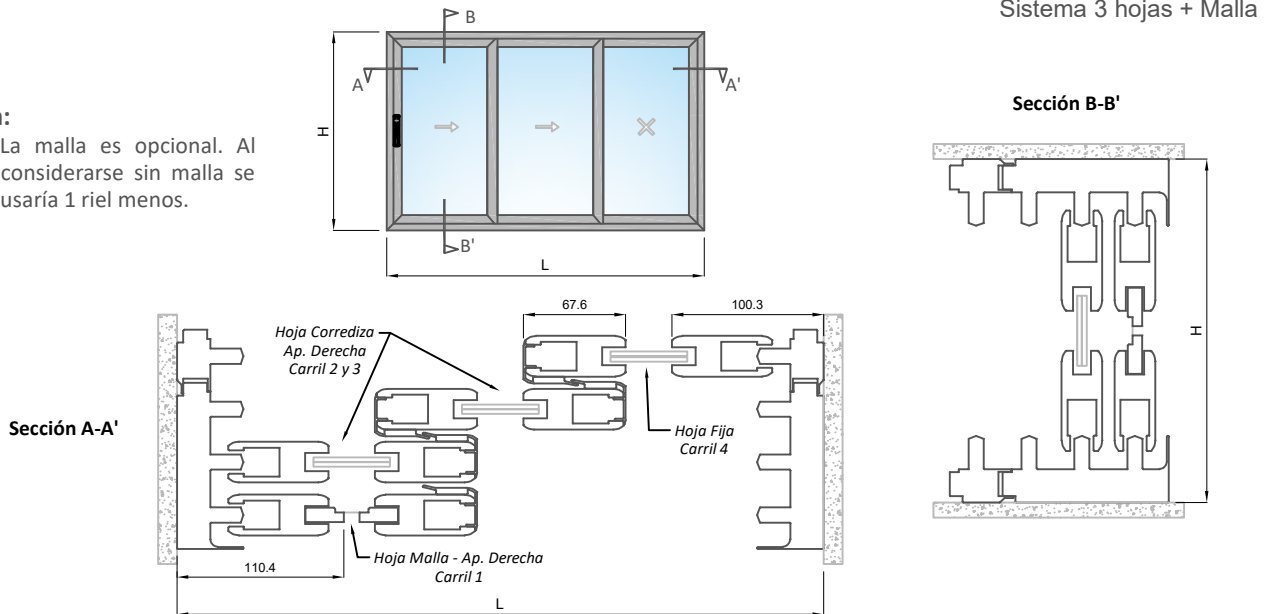

## Escala 1:5

## Europeo 3 carriles

Sistema 3 hojas + Malla

**Nota:**

- La malla es opcional. Al considerarse sin malla se usaría el marco de 2 rieles FI-3445.

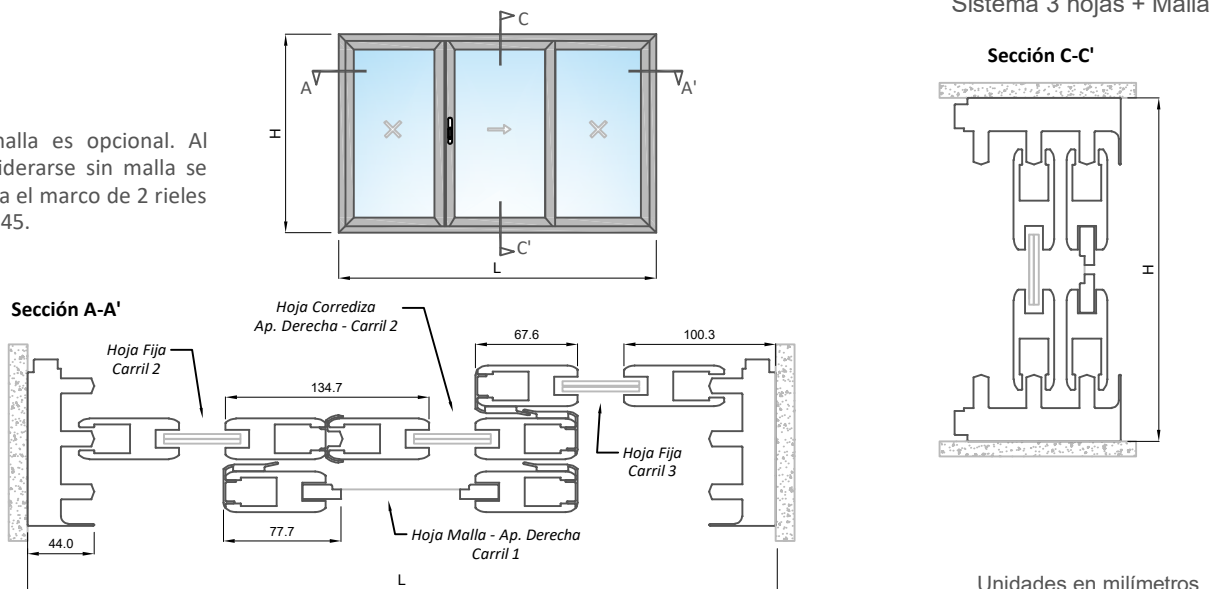

Unidades en milímetros

## Europeo 3 carriles

Escala 1:5

Sistema 3 hojas + 2 Mallas

**Nota:**

- La malla es opcional. Al considerarse sin malla se usaría el marco de 2 rieles FI-3445.

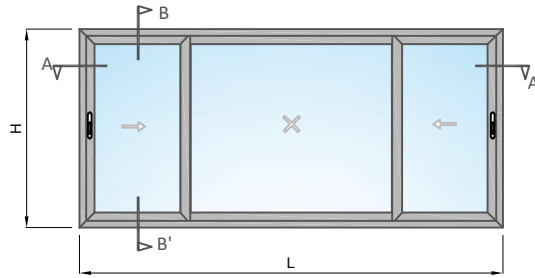

Sección B-B'

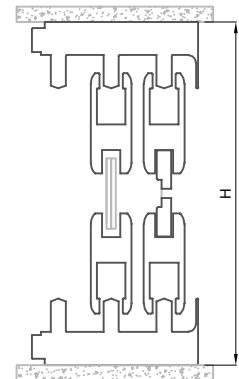

**Corrediza por interior**  
**Sección A-A'**

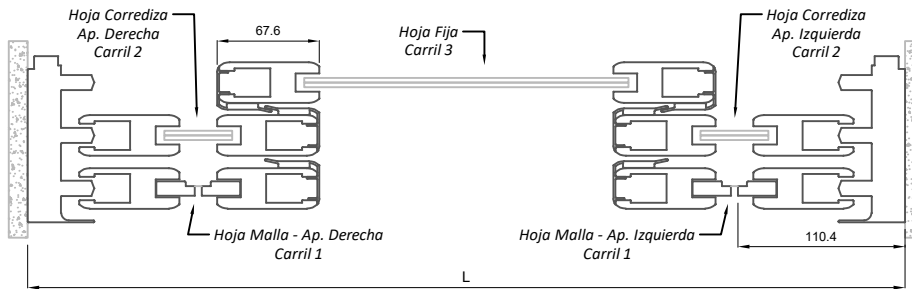

Sección B-B'

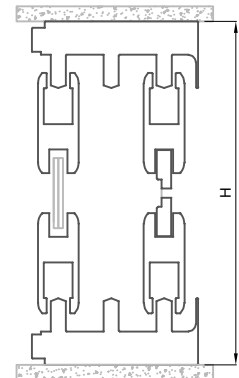

**Corrediza por exterior**  
**Sección A-A'**

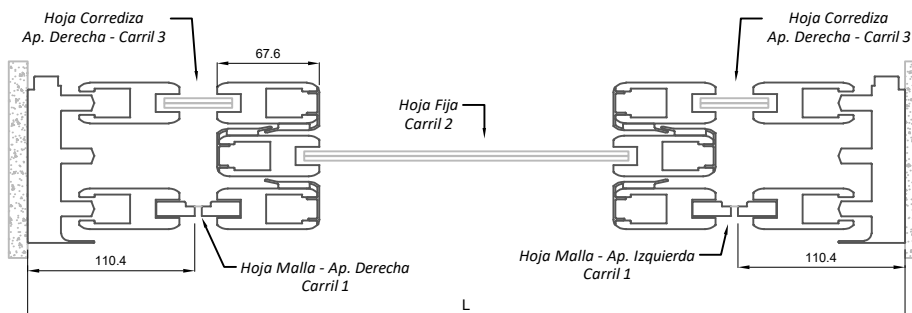

## Europeo 3 carriles

Escala 1:5

Sistema 4 hojas + 2 Mallas

**Nota:**

- La malla es opcional. Al considerarse sin malla se usaría el marco de 2 rieles FI-3445.

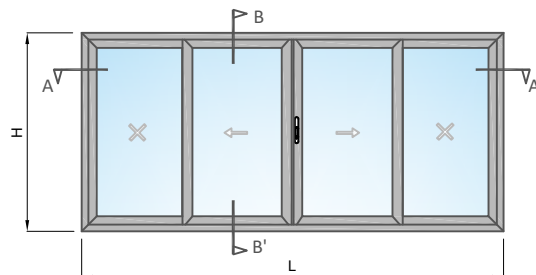

Sección B-B'

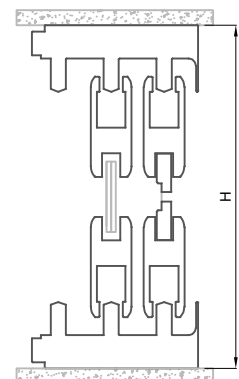

**Corrediza por interior**  
**Sección A-A'**

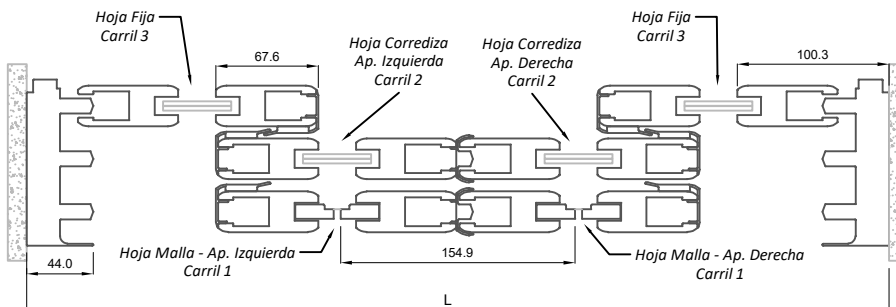

**Corrediza por exterior**  
**Sección A-A'**

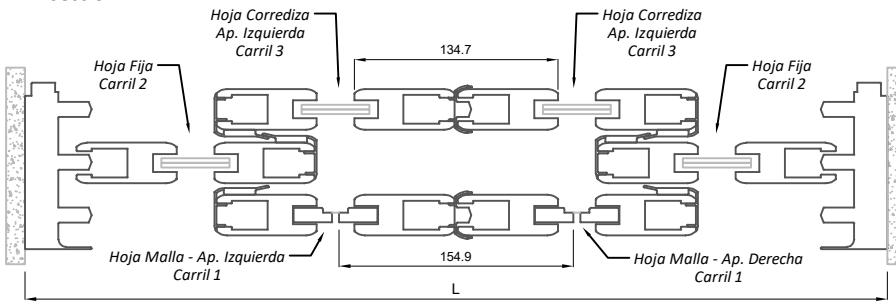

**Sección B-B'**

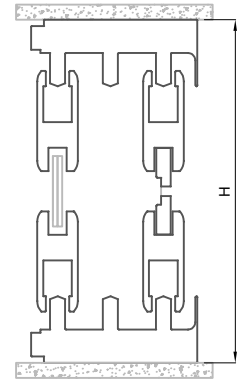

## Europeo 5 carriles

Escala 1:5

Sistema 4 hojas + Malla

**Nota:**

- La malla es opcional. Al considerarse sin malla se usaría 1 riel menos.

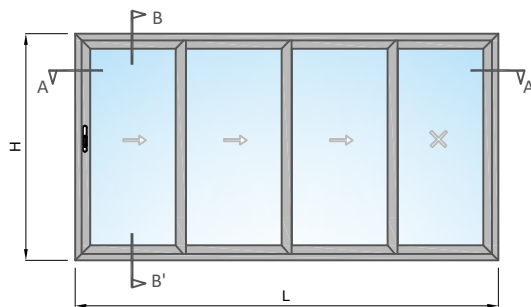

**Sección B-B'**

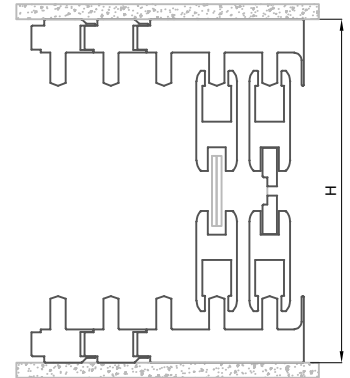

**Sección A-A'**

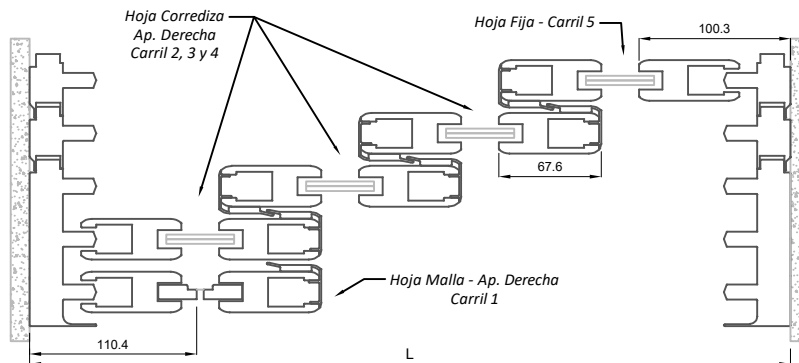

## Europeo 4 carriles

Escala 1:5

Sistema 5 hojas + 2 Mallas

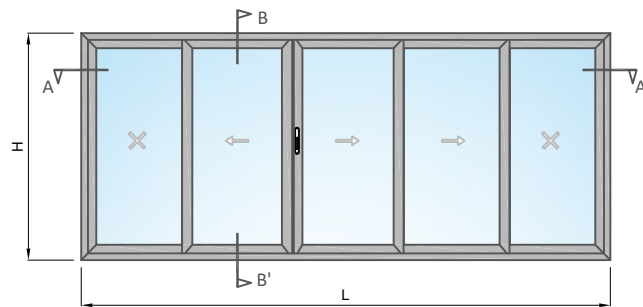

**Sección B-B'**

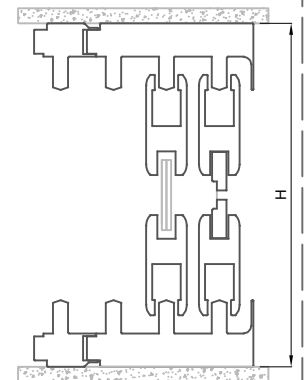

**Sección A-A'**

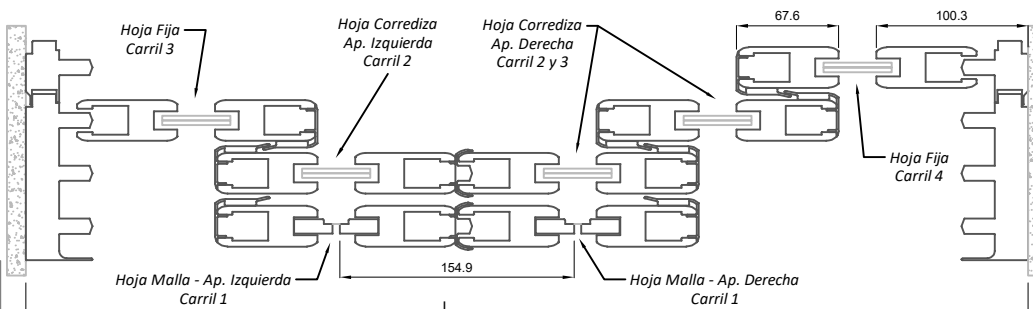

**Nota:**

- La malla es opcional. Al considerarse sin malla se usaría 1 riel menos.

Escala 1:5

Europeo 6 carriles

Sistema 5 hojas + Malla

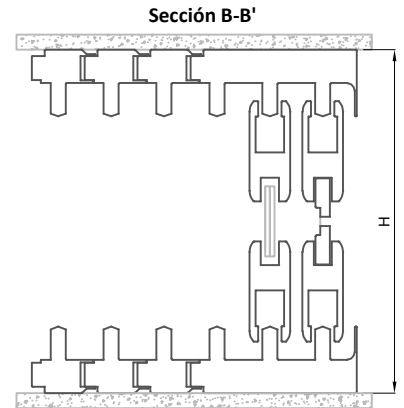
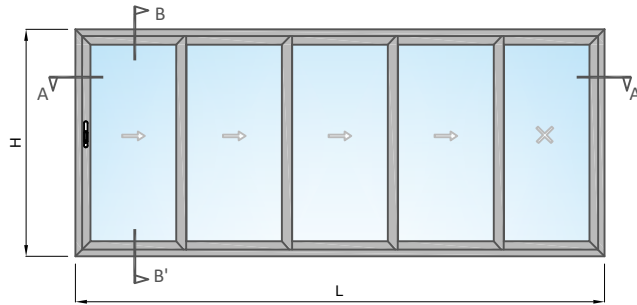

Sección A-A'

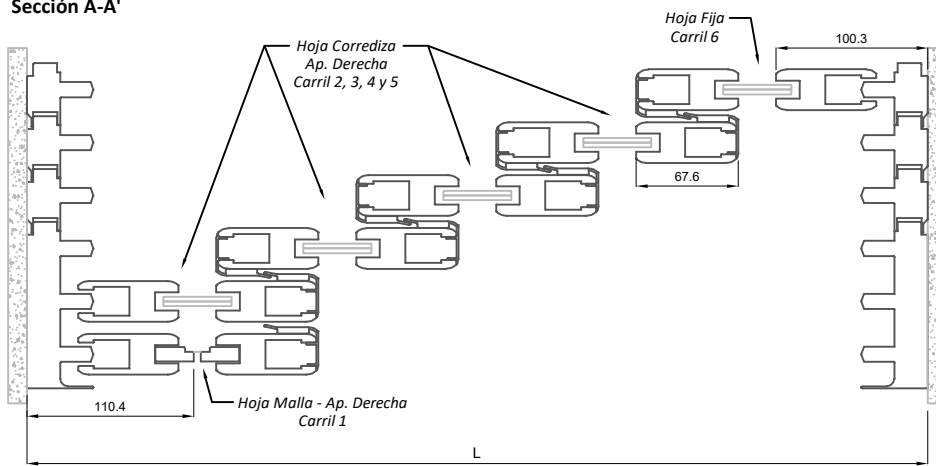

**Nota:**

- La malla es opcional. Al considerarse sin malla se usaría 1 riel menos.

Escala 1:5

Europeo 4 carriles

Sistema 6 hojas + 2 Mallas

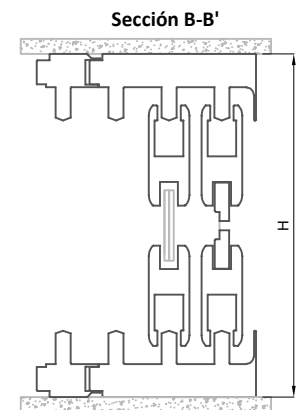
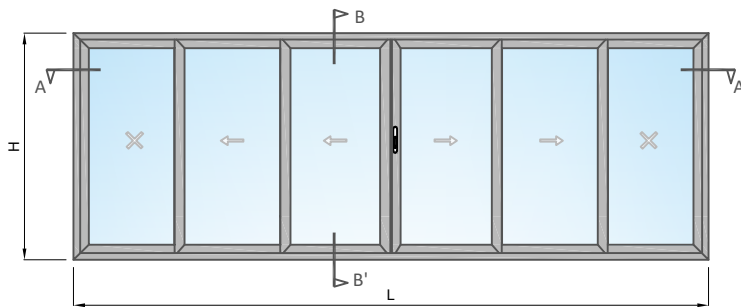

**Nota:**

- La malla es opcional. Al considerarse sin malla se usaría 1 riel menos.

Sección A-A'

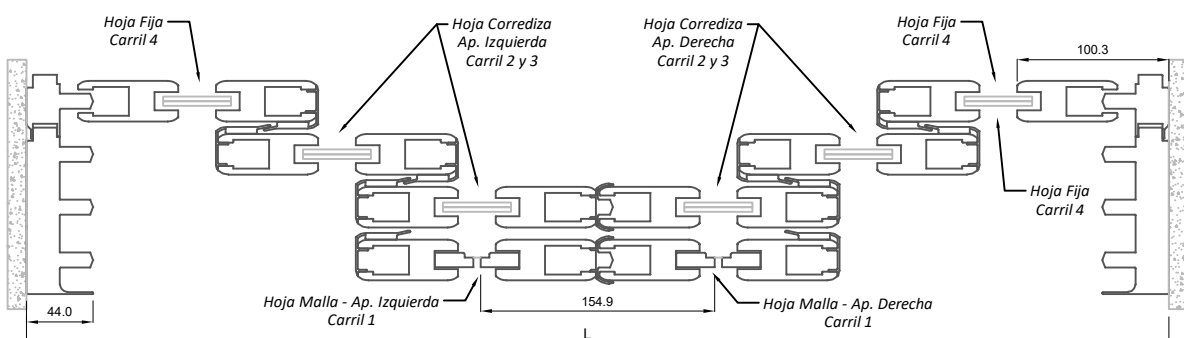

Unidades en milímetros

EU-A

11

## Detalles de cortes de piso

Escala 1:4

Secciones genéricas

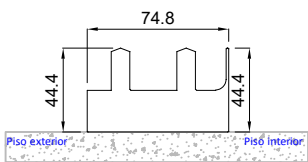
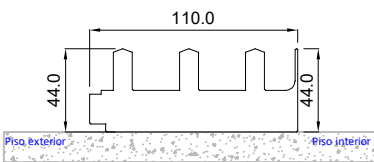
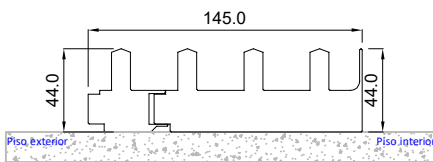
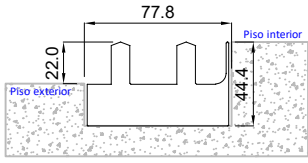
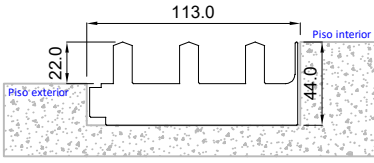
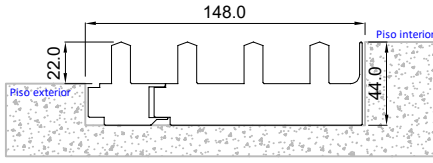
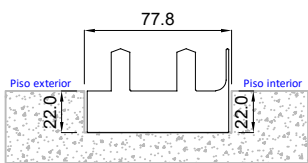
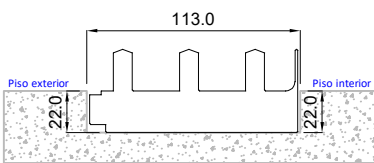
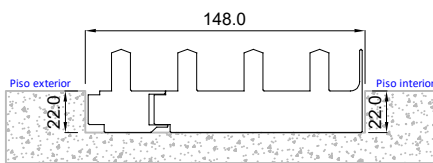
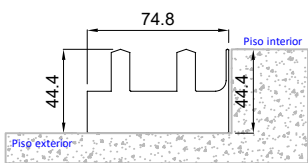
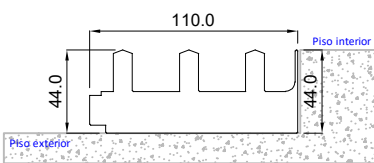
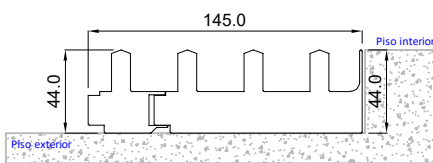
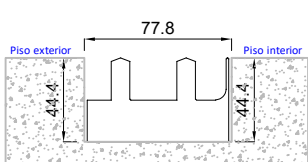
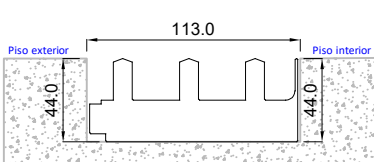
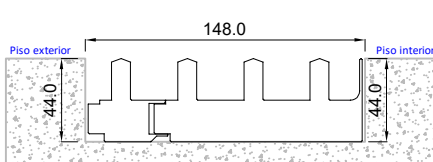
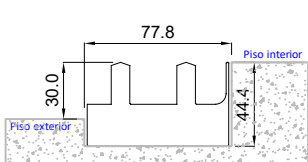
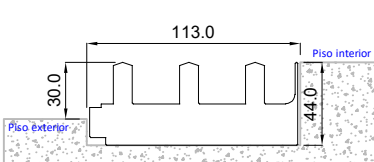
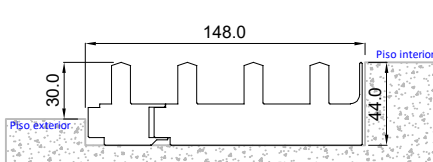
	EU - 2 Rieles	EU - 3 Rieles	EU - 4 Rieles
<b>Opción #1</b>			
<b>Opción #2</b>			
<b>Opción #3</b>			
<b>Opción #4</b>			
<b>Opción #5</b>			
<b>Opción #6</b>			

## Detalles de cortes de piso

Escala 1:4

Secciones genéricas

### EL - 5 Rieles

### EL - 6 Rieles

Opción #1

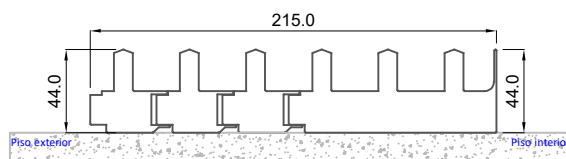
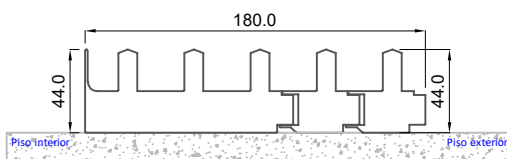

Opción #2

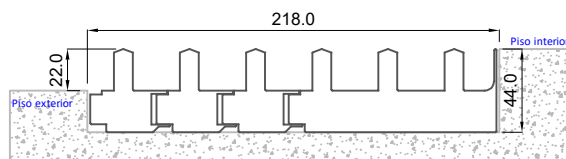
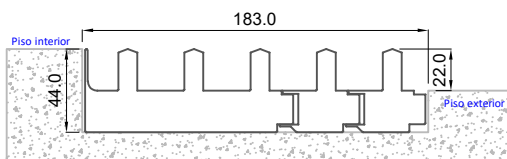

Opción #3

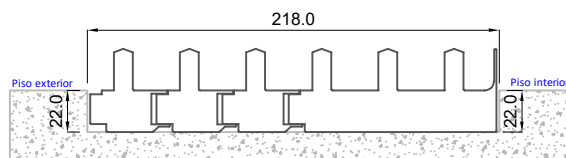
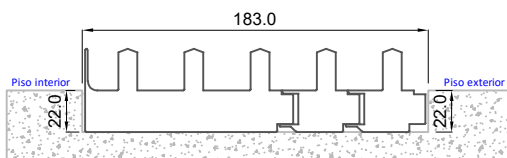

Opción #4

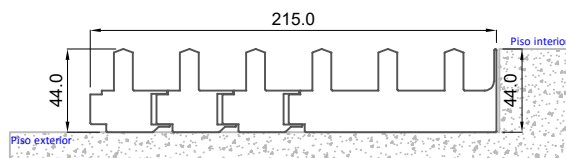
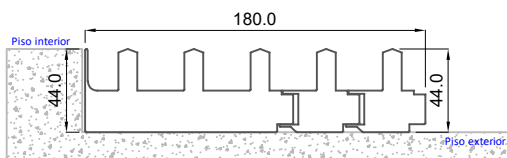

Opción #5

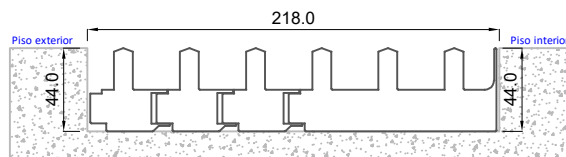
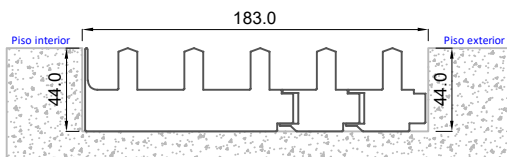

Opción #6

